

# Concerning Compact Discs

Only compact discs bearing this mark can be used with this unit.



## How to remove a disc from its case

## How to store the disc in its case



## How to hold a disc



## If the surface is dirty

Wipe it with a damp cloth and then wipe dry. Wipe from the center toward the outer circumference.

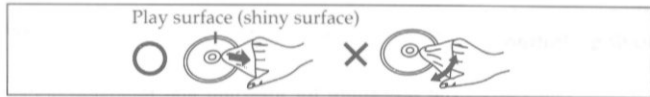

## If moisture has formed on a disc

When moisture has formed because the disc was brought suddenly into a warm room from a cold environment, wipe it off using a soft dry cloth.

## When storing discs

Avoid locations which are

- Exposed to direct sunlight.
- Susceptible to high levels of humidity or dust.
- Directly exposed to heat from a heating appliance.
- On top of a car dashboard or near the rear window.

## Handling precautions

- Do not attach labels or stickers to CD's. Do not use CDs with exposed adhesive from sellotape or left over peeled off stickers.
- Do not use scratch-proof protectors or covers other than those specified for use with this unit.

## Portable CD player

# Panasonic

## Dear Customer

## Operating Instructions

Thank you for purchasing this product. For optimum performance and safety, please read these instructions carefully.

## SL-S120/SL-S125



The model number and serial number of this product can be found on either the back or the bottom of the unit.

Please note them in the space provided below and keep for future reference.

MODEL NUMBER \_\_\_\_\_

SERIAL NUMBER \_\_\_\_\_



## Supplied Accessories

Check the packing carton for these accessories.

AC adaptor ..... 1 pc.  
(RFEA403C-S)

For U.S.A.  
Stereo headphones ..... 1 pc.  
(RFEV705P-KS)

For Canada  
Stereo earphone ..... 1 pc.  
(RFEV317P-KS)

SL-S125 ONLY  
Rechargeable Ni-Cd batteries ..... 2 pcs.  
(RP-BP60PYS)

Battery carrying case ..... 1 pc.  
(RFKNLS370-K)

Remove the rechargeable batteries from their case before use.

Use numbers indicated in parentheses when asking for replacement parts.  
(Only for U.S.A.) To order accessories call MSC Accessory Dept. 1-800-332-5368.

Before connecting, operating or adjusting this product, please read these instructions completely. Please save this manual.



Matsushita Consumer Electronics Company, Division of Matsushita Electric Corporation of America

One Panasonic Way Secaucus, New Jersey 07094

Panasonic Sales Company, Division of Matsushita Electric of Puerto Rico, Inc. ("PSC")

Ave. 65 de Infantería, Km. 9.5 San Gabriel Industrial Park, Carolina, Puerto Rico 00985

Panasonic Canada Inc.

5770 Ambler Drive, Mississauga, Ontario L4W 2T3

RQT3737-P  
F1196R0

# Precautions

Before using this unit, be sure to read the applicable items of the operating instructions and these safety suggestions carefully.

Afterwards keep them handy for future reference. Take special care to follow the warnings indicated on the unit itself as well as in the operating instructions.

## Safety

- 1. Power Source**—The unit should be connected to power supply only of the type described in the operating instructions or as marked on the unit. Use only the AC adaptor or car adaptor described in the operating instructions when recharging.
- 2. Polarization**—If the unit is equipped with a polarized AC power plug (a plug having one blade wider than the other), that plug will fit into the AC outlet only one way. This is a safety feature. If you are unable to insert the plug fully into the outlet, try reversing the plug. If the plug should still fail to fit, contact your electrician to replace your obsolete outlet. Do not defeat the safety purpose of the polarized plug.
- 3. Care of AC adaptor**—Take care that the cord of the AC adaptor should be routed so that they are not likely to be walked on or pinched by items placed upon or against them. Never take hold of the AC adaptor if your hand is wet, and always grasp the plug body when connecting or disconnecting it.
- 4. Nonuse Periods**—When not in use, be sure to disconnect the AC adaptor from the AC power outlet.

## Installation

### Environment

- 1. Water and Moisture**—Do not use this unit near water—for example, near a bathtub, washbowl, swimming pool, or the like. Damp basements should also be avoided.
- 2. Condensation**—Moisture may form on the lens in the following conditions...
  - immediately after a heater has been turned on.
  - in a steamy or very humid room.
  - when the unit is suddenly moved from a cold environment to a warm one. If moisture forms inside this unit, it may not operate properly. To correct this problem wait about one hour for the moisture to evaporate.
- 3. Heat**—Never use or place this unit near a heat source. Do not leave it in an automobile exposed to direct sunlight for a long time with the doors and windows closed as this may deform the cabinet.

### Placement

- 1. Foreign Material**—Care should be taken so that objects do not fall into and liquids are not spilled into the unit. Do not subject this unit to excessive smoke, dust, mechanical vibration, or shock.
- 2. Magnetism**—The unit should be situated away from equipment or devices that generate strong magnetic fields.
- 3. Stacking**—Do not place any objects, on top of the unit.

## Maintenance

(See page 6 for details.)

Clean the cabinet, panel and controls with a soft cloth lightly moistened with mild detergent solution. Do not use any type of abrasive pad, scouring powder or solvent such as alcohol or benzine.

## Service

- 1. Damage Requiring Service**—The unit should be serviced by qualified service personnel when:
  - (a) The AC adaptor is damaged; or
  - (b) Objects have fallen or liquid has been spilled into the unit; or
  - (c) The unit has been exposed to rain; or
  - (d) The unit does not appear to operate normally or exhibits a marked change in performance; or
  - (e) The unit has been dropped, or the enclosure damaged.
- 2. Servicing**—The user should not attempt to service the unit beyond that described in the operating instructions. All other servicing should be referred to an authorized service personnel.  
(Only for U.S.A.)  
Call 1-800-545-2672 for the address of an authorized factory servicenter.

# Power Supply Preparations

Refer to the specifications (page 4) for information on operating times when using rechargeable batteries or dry-cell batteries.

## Using rechargeable batteries

Obtain the optional rechargeable batteries for SL S120. Make sure to recharge the batteries before using them. The unit cannot be used to charge rechargeable batteries other than those specifically designed for it.

- Supplied batteries (RP-BP60)
- Optional batteries (SH-CDB8D)

### Recharging procedure

- 1 Insert the special rechargeable batteries into the unit

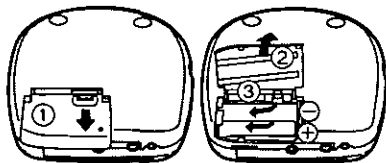

- 2 Connect the AC adaptor

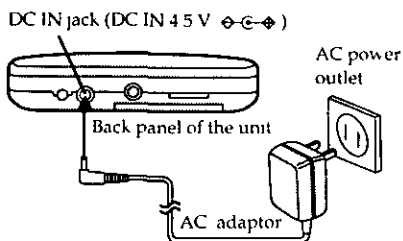

- 3 When recharging is complete, unplug the AC adaptor from the power outlet and the DC IN jack

### Notes

- It takes approximately three hours to fully recharge the rechargeable batteries.
- Rechargeable batteries have a service life of approximately 300 charge-discharge cycles. If the operating time on one full charge becomes noticeably shorter than it used to be, the battery has reached the end of its service life and should be replaced.
- You can operate the unit with the AC adaptor while recharging the batteries, but it will lengthen the recharging time.
- The AC adaptor and rechargeable batteries may become warm while recharging is in progress. This is not a malfunction.

### If the battery lid comes loose

Slide the lid back into place horizontally.

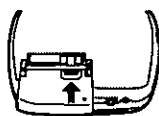

### Removing batteries

Push up on the battery in the direction indicated by the arrow. Then lift it out.

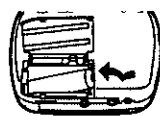

## Using the AC adaptor

### Connect the AC adaptor supplied

Refer to "Using rechargeable batteries" for connection instructions.

## Using the car adaptor (not included)

Be sure to obtain the car adaptor (SH-CDC9) available as an optional accessory. The car adaptor can be used to recharge the unit's batteries while in the car.

### CAUTION

Use only car adaptor Model SH-CDC9 manufactured by Matsushita Electric Industrial Co., Ltd.

## Using dry-cell batteries (not included)

After disconnecting the AC adaptor, insert two AA size (LR6) alkaline batteries.

The procedure for inserting and removing dry-cell batteries is identical to that for rechargeable batteries.

## Battery indicator

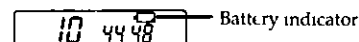

This indicator flashes on and off when the batteries are almost out of power. Power is cut off completely a short while later.

**Rechargeable batteries** Recharge batteries  
**Dry-cell batteries** Replace batteries with new ones

### Notes

- The length of time the unit will continue to operate between when the battery indicator starts flashing and when the power is cut off differs depending on the type of batteries used.
- The battery indicator may not flash if rechargeable batteries other than those designated by Panasonic are used.

## Accidental Operation Prevention Function

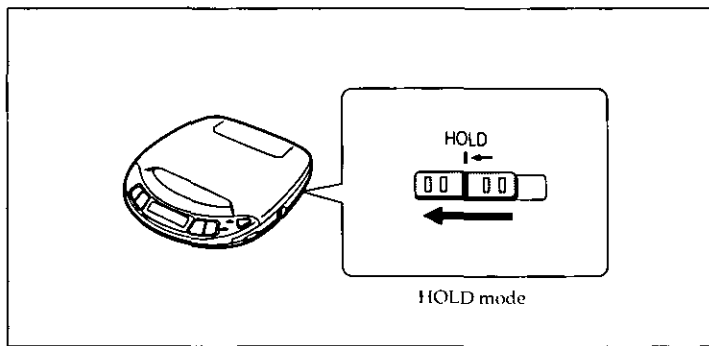

This function causes the unit to ignore short accidental button presses. (The disc lid can still be opened and closed.)

### The misoperation prevention function prevents the following

- Powering on the unit accidentally (which can cause the batteries to go dead)
- Play being cut off unexpectedly in the middle of a selection.

### To use the accidental operation prevention function

Set HOLD to the HOLD position.

### "hold" Indication

When the unit is in hold status, pressing any operation button (other than the OPEN button) causes the indication "hold" to appear on the display.

### When the unit is powered off

The "hold" indication appears only when the ►|| button is pressed.

### Before operating the buttons

Be absolutely sure to move HOLD to release the unit from the hold mode.

## Locations of Controls

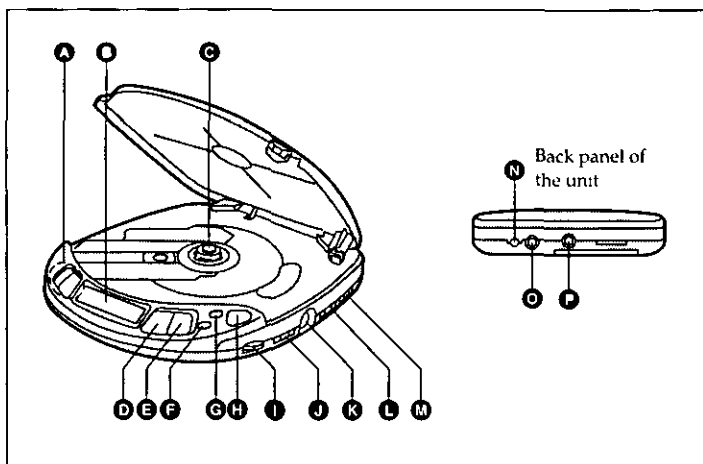

- A Skip/search buttons (◀◀, ▶▶) •SKIP •SEARCH
- B Display
- C Push button (PUSH)
- D Play/pause button (▶ ||)
- E Stop/power off button (■, POWER OFF)
- F Memory/recall button (MEMORY/RECALL)
- G Repeat button (REPEAT)
- H Open button (OPEN)

- I Headphones volume control (VOLUME)
- J XBS selector (XBS)
- K Headphones jack (📞)
- L Play mode selector (RESUME, NORMAL, RANDOM)
- M Hold switch (HOLD)
- N Out jack (OUT)
- O DC in jack (DC IN 4.5 V ⚡)
- P Hole for car insulator mounting screw

# Sequential Play Basic Play

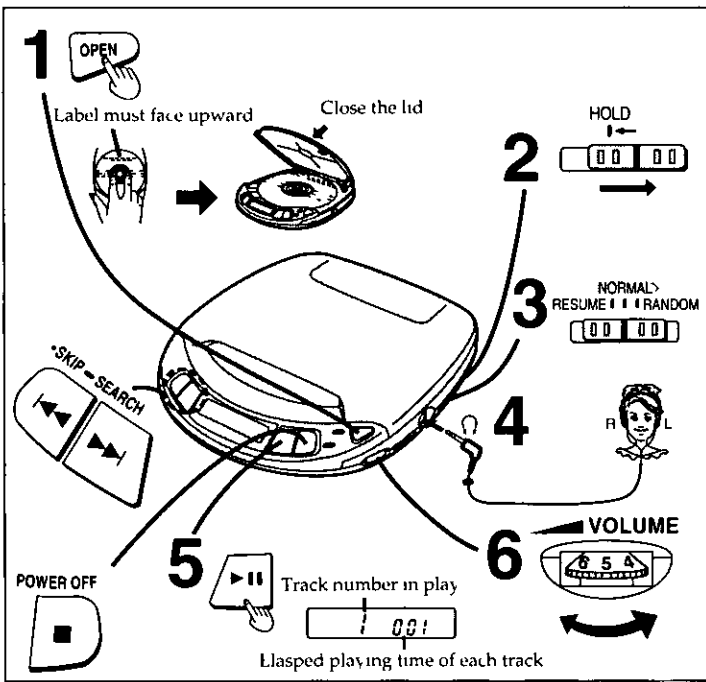

## Following steps 1-6

In step 4 connect the stereo headphones/earphones to the  $\phi$  jack (Plug in firmly)

• Play stops automatically when all the tracks have been played

• If the unit has been connected to the car audio system, adjust the volume level between 4 and 6 on the unit then adjust the volume level on the system

Operation	Button	Display/reference
To pause play	Press during play	Press again to resume play
To stop play <b>Stop mode</b>	Press during play	Total number of tracks Total playing time
To turn off the unit <b>Off mode</b>	Press during stop mode	
Skip forward/ backward (skip function)	Press during play	<ul style="list-style-type: none"> <li>• During program play these buttons are used to skip forward or back through the programmed sequence of tracks</li> <li>• During random play the skip buttons cannot be used to skip back to tracks that were played previously in the random sequence</li> <li>• During program play random play or 1 track repeat play search operation is limited to the current track only</li> </ul>
Rapid forward/ backward (search function)	(Backward) (Forward) Keep depressed during play	

### For your reference

#### "no disc" indication

This indication appears for about 30 seconds if the  $\text{▶} \text{||}$  button is pressed when no disc is loaded in the unit or if the disc is not completely seated

#### "OPEN" indication

This indication appears for about 10 minutes when the cover is opened (However the indication does not appear when the unit is powered off)

### Removing discs

After the disc has stopped rotating press the  $\text{PUSH}$  button to release the disc (To protect the disc never open the cover while it is playing)

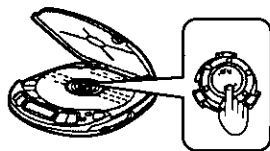

### Note

Never insert foreign objects into the unit body

### Auto power off function

If the unit is left in stop or paused status for approximately 10 minutes, the unit powers itself off automatically in order to prevent the battery from running down

# Other Play Methods

The letters such as  $\text{A}$  in the various illustrations refer to the descriptions in the "Location of Controls" (see page 2) section

## Skip play

The disc plays from the specific track through to the end then play stops automatically

Preparation Put unit in stop mode



2 Select the desired track

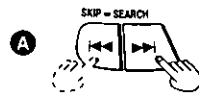

## Random play

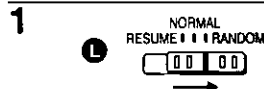

Release



### For your reference

- It is also possible to press the  $\text{▶} \text{||}$  button while the unit is in stop status to change the first track to be played (All tracks are played eventually regardless of which is played first)
- Program play is not possible in the random mode

## Resume play

This function allows you to listen from the beginning to the track where play stopped because the unit was powered off (or switched to stop status) It is useful when listening to CDs in the car etc

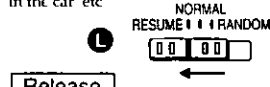

Release

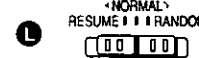

### For your reference

- If the RESUME, NORMAL, RANDOM (play mode selector) slider is put in the RESUME position the all repeat function will be activated automatically as soon as the unit is powered on
- If power is cut off near the end of a track (power off status) playback may resume from the beginning of the next track in some cases
- If the unit is powered off while a disc was playing and then a new disc is inserted play will begin from the middle of the new disc because the unit remembers the position where play stopped on the old disc

## Program play

Up to 24 tracks can be entered in the programmed sequence

Preparation Put unit in stop mode

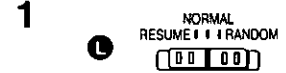

2 Select the desired track



3 Register in sequence

(The indication  $\text{M}$  and the programmed sequence appear on the display panel)



4 Repeat steps 2 and 3 to program all the desired tracks



■ To program the same track in the sequence more than once

After step 3 press MEMORY/RECALL the desired number of times

■ If "f" is displayed

No more tracks may be added to the sequence

■ To confirm the contents of the programmed sequence

Press MEMORY/RECALL while the disc is playing (The number of the programmed tracks appear on the display panel in sequence)

■ To delete the entire programmed sequence

Press  $\blacksquare$  POWER OFF

## Repeat function

Press REPEAT while disc is playing or when unit is in stop status



### For your reference

If REPEAT is pressed during program play, only the tracks in the programmed sequence are repeated

(The indication ALL is not displayed)

The setting is switched in the sequence indicated below each time REPEAT is pressed

1-track repeat (1  $\text{↺}$ )

One track is repeated

↓ All-track repeat (ALL  $\text{↺}$ )

All the tracks on the disc are repeated

↓ Cancel

## Changing the sound quality

### XBS ON

Select this setting to boost the low-range response

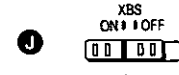

### OFF

Select this setting to turn off the S-XBS function

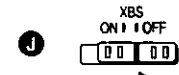

### Note

This function is available except when using the OUT jack

# Specifications

<b>Audio</b>	
No. of channels	2 (left and right stereo)
Frequency response	20 to 20 000 Hz (+0.5 dB -1.5 dB)
Output voltage	0.6 V (50 mV)
S/N	More than 94 dB
Wow and flutter	Below measurable limit
DA converter	1 bit MASH
Headphones output level	Max. 9 mW + 9 mW / 16 Ω (variable)
<b>Pickup</b>	
Light source	Semiconductor laser
Wavelength	780 nm
<b>General</b>	
Operational temperature range	0°C-40°C (32°F-104°F)
Rechargeable temperature range	5°C-40°C (41°F-104°F)
Power supply	DC 4.5V
<b>Power consumption</b>	
Using AC adaptor	4.3 W

**Play time**  
[When used in hold mode, at 25°C (77°F) temperature and on flat and stable surface.]

2 alkaline batteries	About 10 hours
Rechargeable batteries	About 3 hours

The play time may be less depending on the operating conditions

<b>Recharging time</b>	About 3 hours
<b>Dimension (W×H×D)</b>	128×28.0×144 mm (5 1/4" × 1 1/4" × 5 1/2")
<b>Weight</b>	265 g (9.4 oz) (with batteries) 220 g (7.8 oz) (without batteries)

**Note**  
Specifications are subject to change without notice  
Weight and dimensions are approximate

MASH is a trademark of NTT

# Troubleshooting Guide

Before requesting service for this unit check the chart below for a possible cause of the problem you are experiencing. Some simple checks or a minor adjustment on your part may eliminate the problem and restore proper operation.

If you are in doubt about some of the check points or if the remedies indicated in the chart do not solve the problem, refer to the directory of Authorized Service Centers (enclosed with this unit) to locate a convenient service center or consult your dealer for instructions.

(In U.S.A. consult MSC Authorized Servicecenters for detailed instructions or call 1-800-545-2672 for the address of an authorized factory servicenter.)

Problem	Check this
<b>Cannot close cover</b>	Is the disc properly secured in place?
<b>Cannot play discs</b>	<ul style="list-style-type: none"> <li>Is the unit in hold status?</li> <li>Is the disc properly secured in place?</li> <li>Is there moisture condensation on the lens? (Wait for about an hour and then try again.)</li> </ul>
<b>Cannot remove disc</b>	Did you press the PUSH button to release the disc?
<b>Tracks on disc do not play in order, starting with the first track</b>	Is the RESUME NORMAL, RANDOM (play mode selector) slider in the NORMAL position?
<b>Cannot hear music—too noisy</b>	<ul style="list-style-type: none"> <li>Are the headphones/carphones plug inserted all the way?</li> <li>Are the plugs dirty?</li> </ul>
<b>TV picture is distorted Radio reception is noisy</b>	Are you using the unit body too near a TV or tuner? (If the TV or tuner is connected to a simple indoor antenna connect it to an outdoor antenna.)

# Using the Unit with Optional Accessories

## Using the unit with an audio system

Using the stereo connection cable (not included) you can hear CDs on your audio system.

- Connect the cable to the amplifier after turning off its power.
- Do not connect the cable to the PHONO jacks on the amplifier.
- Obtain the optional connecting cable if the amplifier comes with mini phone jacks.
- Adjust the volume level on the amplifier.

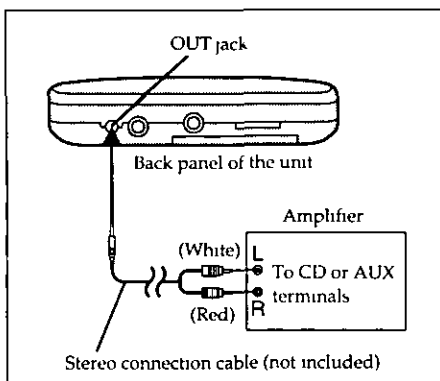

## Using the unit with a car audio system stereo

### Items to be purchased

#### For connection to the car audio system

Car stereo cassette adaptor (SH-CDM9A)

Connect the car stereo cassette adaptor to the unit's headphone jack.

(When doing this, keep the unit's VOLUME control at a setting between 4 and 6.)

#### For securing the unit and connecting the power supply

- Car adaptor (SH-CDC9)
- Car mounting kit (SH-CDF7)
- Car mounting arm, Car insulator

### Note

It may not be possible to use the unit with some types of car stereo owing to restrictions imposed by the construction of the car stereo cassette adaptor.

For further details, refer to the instructions of the part concerned.

## For your protection

Complete and immediately mail the Product Analysis Card so that we may contact you directly in the event a safety notification is issued in accordance with the 1972 Consumer Product Safety Act, or for other reasons Panasonic may deem necessary. Also, we ask that you complete the questionnaire so we may analyze your comments and, in this way, help us evaluate customer needs.

## If you ship the product

Carefully pack and send it prepaid, adequately insured and preferably in the original carton. Attach a postage-affixed letter, detailing the complaint, to the outside of the carton.

**Do NOT send the product to the Executive or Regional Sales offices. They are NOT equipped to make repairs.**

## Customer's Record

Model No. _____	Dealer's Name _____
Serial No. _____ or _____	_____
Code No. _____	Dealer's Address _____
Date of Purchase _____	_____

**Customer Service Center 2F-3, One Panasonic Way, Secaucus, NJ 07094 (Headquarters) 201-348-9090 (9 00am-8 00pm Monday-Friday, EST)**

**AUTHORIZED SERVICENTERS • PARTS DISTRIBUTOR LOCATIONS**

To locate an independent authorized servicer or parts distributor in your area, within the USA dial toll free **1-800-545-2672**, 24 hours a day, 7 days a week

**PRODUCT REPAIRS**

**Factory Servicenters**

**CALIFORNIA**

6550 Katella Avenue  
Cypress, CA 90630  
Phone (714) 373 7425  
Fax (714) 894 8534

800 Dubuque Avenue  
5 San Francisco CA 94080  
Phone (415) 871 6373  
Fax (415) 871 6840

20201 Sherman Way  
Suite 102  
Canoga Park, CA 91306  
Phone (818) 709 1775  
Fax (818) 709 2165

3878 Ruffin Road  
Suite A  
San Diego, CA 92123  
Phone (619) 560-9200  
Fax (619) 560-1831

**COLORADO**

1640 South Abilene Suite D  
Aurora CO 80012  
Phone (303) 752 2024  
Fax (303) 752 0610

**FLORIDA**

3700 North 29th Avenue  
Suite 102  
Hollywood FL 33020  
Phone (954) 925 2880  
Fax (954) 925 5224

4710 Eisenhower Boulevard  
Suite A1  
Tampa, FL 33634  
Phone (813) 884 4746  
Fax (813) 886-4564

**GEORGIA**

8655 Rosewell Road  
Suite 100  
Atlanta GA 30350  
Phone (770) 518 6301  
Fax (770) 518 6306

**HAWAII**

99 859 Iwaiwa Street  
Aiea Hawaii 96701  
Phone (808) 488 1996  
Fax (808) 486-4369

**ILLINOIS**

•1703 North Randall Road  
Elgin IL 60123  
\*12 30 to 4 30 Mon Fri\*  
Phone (847) 468 5464  
Fax (847) 468 5465

9060 Golf Road  
Niles IL 60714  
Phone (847) 608 1010  
Fax (847) 299 1710

**MARYLAND**

Sulphur Springs  
Business Park  
1638 Sulphur Springs Road  
Baltimore, MD 21227  
Phone (410) 242 2607  
Fax (410) 247-3047

**MASSACHUSETTS**

60 Glacier Drive, Suite C  
Westwood MA 02090  
Phone (617) 329 4280  
Fax (617) 329 0586

\* pick-up/drop-off only

**MICHIGAN**

37048 Van Dyke Avenue  
Sterling Heights, MI 48312  
Phone (810) 939 2060  
Fax (810) 939 2638

**MINNESOTA**

7850 12th Avenue South  
Airport Business Center  
Bloomington, MN 55425  
Phone (612) 854 8624  
Fax (612) 854 2089

**OHIO**

2236 Waycross Road  
Cincinnati, OH 45240  
Phone (513) 851 4180  
Fax (513) 851 8443

**PENNSYLVANIA**

2221 Cabot Boulevard West  
Suite B  
Langhorne PA 19047  
Phone (215) 741-0661  
Fax (215) 741-0521

Chartiers Valley Shopping Center  
1025 Washington Pike  
Bridgeville PA 15017  
Phone (412) 257 4522  
Fax (412) 257 4650

**TENNESSEE**

919 8th Avenue South  
Nashville TN 37203  
Phone (615) 244-4434  
Fax (615) 244 6713

**TEXAS**

7482 Harwin Drive  
Houston TX 77036  
Phone (713) 781 1528  
Fax (713) 781 0643

13615 Welch Road  
Suite 101  
Farmers Branch, TX 75244  
Phone (214) 385 1975  
Fax (214) 960-7626

**WASHINGTON**

20425 84th Avenue South  
Kent, WA 98032  
Phone (206) 872 7922  
Fax (206) 872-0918

**Service in Puerto Rico**

Matsushita Electric  
of Puerto Rico, Inc  
Panasonic Sales Company/  
Factory Servicer  
Ave 65 de Infantaria Km 9.5  
San Gabriel Industrial Park  
Carolina, Puerto Rico 00985  
Phone (809) 750 4300  
Fax (809) 768 2910

**REPAIR INQUIRIES**

**Regional Customer Care Department**

**EAST (PCE)**

2221 Cabot Boulevard West  
Suite A  
Langhorne PA 19047  
Phone (215) 741-0676  
Fax (215) 750 6492

Covers  
CT DE ME MD MA  
NH, NJ, NY, PA, RI, VT  
VA DC WV

**EAST (PCE)**

1225 Northbrook parkway  
Suite 2 390  
Suwanee GA 30174  
Phone (404) 338 6860  
Fax (404) 338 6548

Covers  
AL, FL, GA  
MS NC SC TN

**CENTRAL (PCC)**

1707 North Randall Road  
Elgin IL 60123  
Phone (847) 468 5530  
Fax (847) 468 6528

Covers  
AR IL IN, IA, KS, KY,  
LA MI MN MO NE  
ND, OK, SD, TX, WI, OH

**WEST (PCW)**

6550 Katella Avenue  
Cypress, CA 90630  
Phone (714) 373-7440  
Fax (714) 373-7447

Covers  
AK AZ CA CO, ID  
MT NV NM OR UT  
WA WY HI

**ACCESSORY PURCHASES**

**1-800-332-5368** (Consumer Orders Only) Matsushita Services Company 20421 84th Avenue South Kent, WA 98032  
(6 am to 6 pm Monday-Friday, 6 am to 10 30 am Saturday, PST) (Visa, Mastercard, Discover card, American Express, Check)

MATSUSHITA CONSUMER ELECTRONICS  
COMPANY, DIVISION OF MATSUSHITA  
ELECTRIC CORPORATION OF AMERICA  
One Panasonic Way Secaucus  
New Jersey 07094

PANASONIC SALES COMPANY, DIVISION  
OF MATSUSHITA ELECTRIC  
OF PUERTO RICO INC ("PSC")  
Ave 65 de Infantaria Km 9.5  
San Gabriel Industrial Park  
Carolina Puerto Rico 00985  
Tel (809) 750 4300  
FAX (809) 768 2910

**PANASONIC AUDIO PRODUCTS  
Limited Warranty**

Matsushita Consumer Electronics Company or Panasonic Sales Company (collectively referred to as "The warrantor") will repair this product with new or refurbished parts free of charge in the U.S.A or Puerto Rico from the date of original purchase in the event of a defect in materials or workmanship as follows

**AUDIO COMPONENTS, RADIOS, COMPACT DISC PLAYERS, VIDEO CD PLAYERS AND HOME ENTERTAINMENT SYSTEMS**—For one (1) year

**ACCESSORIES, HEADPHONES AND CARTRIDGES**—(when applicable) For ninety (90) days

**BATTERIES**—(when applicable)—New rechargeable batteries in exchange for defective rechargeable batteries—For ten (10) days Non rechargeable batteries are not warranted

**RECHARGEABLE BATTERY PACKS**—(when applicable)—New rechargeable battery packs in exchange for defective rechargeable battery packs for (90) days Non-rechargeable battery packs are not warranted

Carry-in or mail-in service in the continental U.S.A can be obtained during the warranty period from a Matsushita Services Company (MSC) Factory Servicer listed in the Servicer Directory Or call 1-800-545-2672 toll free to locate an authorized MSC Servicer Carry in or mail-in service in Puerto Rico can be obtained during the warranty period by calling the telephone numbers listed in the Servicer Directory

This warranty is extended only to the original purchaser. A purchase receipt or other proof of date of original purchase will be required before warranty service is rendered

This warranty only covers failures due to defects in materials or workmanship

which occur during normal use and does not cover normal wear to the stylus (when applicable) or dealer installed cartridge or stylus. It does not cover damage which occurs in shipment or failures which are caused by products not supplied by the warrantor or failures which result from accident misuse abuse neglect mishandling misapplication faulty installation set up adjustment improper maintenance alteration improper antenna inadequate signal pick-up maladjustment of consumer controls, modification, or commercial use of product, or service by anyone other than an MSC Factory Servicer or authorized MSC Servicer or damage that is attributable to acts of God

**LIMITS AND EXCLUSIONS**

There are no express warranties except as listed above

THE WARRANTOR SHALL NOT BE LIABLE FOR INCIDENTAL OR CONSEQUENTIAL DAMAGES RESULTING FROM THE USE OF THIS PRODUCT OR ARISING OUT OF ANY BREACH OF THIS WARRANTY INCLUDING WITHOUT LIMITATION DAMAGE TO TAPES RECORDS OR DISCS ALL EXPRESS AND IMPLIED WARRANTIES INCLUDING THE WARRANTIES OF MERCHANTABILITY AND FITNESS FOR A PARTICULAR PURPOSE ARE LIMITED TO THE APPLICABLE WARRANTY PERIOD SET FORTH ABOVE Some states do not allow the exclusion or limitation of incidental or consequential damages or limitations on how long an implied warranty lasts so the above exclusions or limitations may not apply to you

This warranty gives you specific legal rights and you may also have other rights which vary from state to state

If a problem with this product develops during or after the warranty period you may contact your dealer or Servicer. If the problem is not handled to your satisfaction then write to the Consumer Affairs Division at the company address indicated above

# Cautions

## Listening caution



Do not play your headphones or earphones at a high volume. Hearing experts advise against continuous extended play.

If you experience a ringing in your ears, reduce volume or discontinue use.

Do not use while operating a motorized vehicle. It may create a traffic hazard and is illegal in many areas.

You should use extreme caution or temporarily discontinue use in potentially hazardous situations.

Even if your headphones or earphones is an open-air type designed to let you hear outside sounds, don't turn up the volume so high that you can't hear what's around you.

Sound can be deceiving. Over time your hearing "comfort level" adapts to higher volumes of sound. So what sounds "normal" can actually be loud and harmful to your hearing.

Guard against this by setting your equipment at a safe level BEFORE your hearing adapts.

To establish a safe level:

- Start your volume control at a low setting.
- Slowly increase the sound until you can hear it comfortably and clearly, and without distortion.

Once you have established a comfortable sound level:

- Set the dial and leave it there.

## Rechargeable batteries

- Only the RP-BP60/SH-CDB8D batteries can be recharged.
- If the power delivered by the batteries lasts for a very short time after recharging, it means that the battery's service life is over. Do not use them any more.
- Recharging already charged batteries will shorten their service life.
- When recharging batteries for the first time or when they have not been used for a long period of time, the play time may be shorter than usual. In a case like this, repeatedly recharge and discharge the batteries. This will restore them to their regular state.
- Do not allow any metal objects to touch the terminals of rechargeable batteries since this may cause short-circuiting which is dangerous.
- Do not peel off the plastic covering on the rechargeable batteries. Short-circuiting may occur which is dangerous.

## Dry cell batteries/rechargeable batteries

To prevent damage to the batteries and electrolyte leakage, heed the following points:

- Align the ⊕ and ⊖ polarities properly when inserting the batteries.
- Do not mix different types or makes of batteries or old and new batteries.
- Remove the batteries if you do not plan to use the unit for a long period of time.
- Do not throw batteries into a fire and do not short-circuit, disassemble or subject them to excessive heat.
- Do not attempt to recharge dry cell batteries.

## Carrying dry cell batteries/rechargeable batteries around

When putting dry cell or rechargeable batteries in a pocket or bag, ensure that no other metal objects such as a necklace are placed together with them. Contact with metal may cause short-circuiting which, in turn, may cause a fire. Be absolutely sure to carry the rechargeable batteries in the battery carrying case.

## When purchasing rechargeable batteries

As a safety precaution, the portable CD players made by Panasonic have a construction designed to make it impossible to recharge ordinary batteries.

To use rechargeable batteries, be absolutely sure to purchase the rechargeable Ni-Cd batteries designed especially for this unit.

### Special rechargeable Ni-Cd batteries SH-CDB8D (set of 2)

For details, check with your dealer.

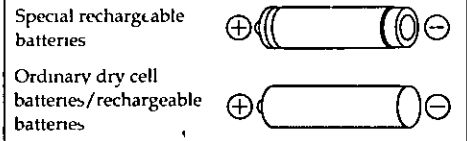

## When driving a car

In the interest of traffic safety, do not operate the unit while driving.

## Maintaining the Lens

Open the lid and clean the lens as shown in the figure. Use a cotton swab to gently wipe off any finger prints. Recommended product: Lens cleaner kit (SZZP1078C).

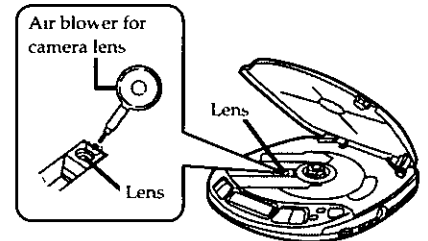

## Product Service

Do not attempt to remove the cover(s) or repair the unit yourself. Refer servicing to qualified personnel only.

## Product information

For product service, product information or assistance with product operation, refer to the servicenter directory.

## User memo

DATE OF PURCHASE \_\_\_\_\_  
 DEALER NAME \_\_\_\_\_  
 DEALER ADDRESS \_\_\_\_\_  
 TELEPHONE NUMBER \_\_\_\_\_

## CAUTION!

**THIS PRODUCT UTILIZES A LASER USE OF CONTROLS OR ADJUSTMENTS OR PERFORMANCE OF PROCEDURES OTHER THAN THOSE SPECIFIED HEREIN MAY RESULT IN HAZARDOUS RADIATION EXPOSURE. DO NOT OPEN COVERS AND DO NOT REPAIR YOURSELF. REFER SERVICING TO QUALIFIED PERSONNEL.**

THE FOLLOWING PHRASES ARE APPLIED ONLY FOR U.S.A.

**POWERED BY NICKEL-CADMIUM BATTERY MUST BE RECYCLED OR DISPOSED OF PROPERLY**

### ATTENTION

The product that you have purchased is powered by a rechargeable battery. The battery is recyclable. At the end of its useful life, under various state and local laws, it may be illegal to dispose of this battery into the municipal waste stream.

Check with your local solid waste officials for details in your area for recycling options or proper disposal.



## WARNING:

**TO REDUCE THE RISK OF FIRE, ELECTRIC SHOCK OR PRODUCT DAMAGE, DO NOT EXPOSE THIS APPLIANCE TO RAIN, SPLASHING, DRIPPING OR MOISTURE**

This device complies with Part 15 of the FCC Rules. Operation is subject to the following two conditions: (1) This device may not cause harmful interference, and (2) this device must accept any interference received, including interference that may cause undesired operation.

## CAUTION:

This equipment has been tested and found to comply with the limits for a Class B digital device, pursuant to Part 15 of the FCC Rules.

These limits are designed to provide reasonable protection against harmful interference in a residential installation. This equipment generates uses and can radiate radio frequency energy and, if not installed and used in accordance with the instructions, may cause harmful interference to radio communications. However, there is no guarantee that interference will not occur in a particular installation. If this equipment does cause harmful interference to radio or television reception, which can be determined by turning the equipment off and on, the user is encouraged to try to correct the interference by one of the following measures:

- Reorient or relocate the receiving antenna.
- Increase the separation between the equipment and receiver.
- Connect the equipment into an outlet on a circuit different from that to which the receiver is connected.
- Consult the dealer or an experienced radio/TV technician for help.

Any unauthorized changes or modifications to this equipment would void the user's authority to operate this device.